

# T 815-7L0R39 29 276 6x6.1R



DEFENCE

## 6x6 HMHD CARGO/TROOP CARRIER

The TATRA 6x6 High Mobility Heavy Duty (HMHD) - Tactical Truck is a member of the most recent development of the latest military family of TATRA trucks designed for rough terrain, difficult climatic and environment conditions. Due to its specific design features, this truck is particularly suitable for expeditionary forces and for deployment overseas.

The 6x6 all-wheel drive chassis employs new development of the independent suspension and backbone tube frame, which are unique characteristics of the TATRA concept chassis proven for more than 90 years. It allows each wheel to move independently, with improved steering, and maximum tire-to-ground contact, while featuring extreme resistance of the chassis against torsion and bending. This is provided by a solid 3D frame formed by connecting the backbone tube with a conventional ladder frame via several cross-members. In addition, the backbone tube frame also protects all driveline components, which are placed inside the backbone tube, against impacts, dust, and humidity. Low service and maintenance costs and service-free design without conventional cardan shaft torque distribution are other benefits of this concept.

Air springs all-round, along with the independent wheel suspension, care for low vertical vibration, and thus provide high ride comfort, enabling also fast drive in rough terrain.

- C-130 transportable • Adjustable vehicle height and clearance • All-wheel drive • Differential locks • CTIS operated on the fly
- Optional add-on armouring kits to be implemented by the end user when needed

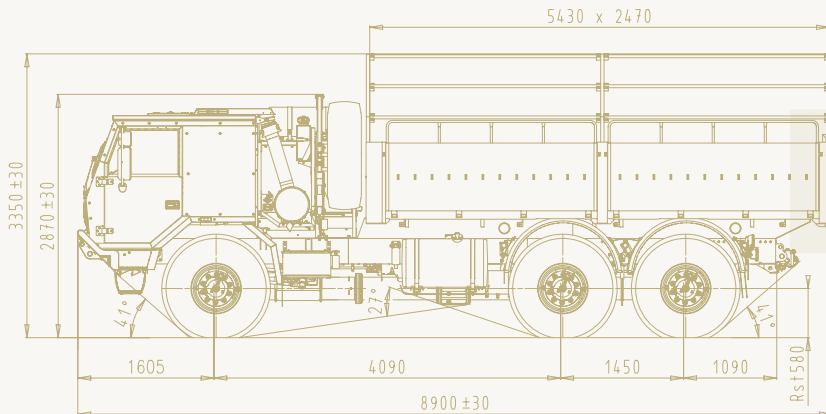

INDEPENDENT SUSPENSION  
SOLID 3D STRUCTURE FRAME

15,100 kg PAYLOAD

6x6 DRIVE

276 kW

TATRA TAKES YOU FURTHER

tatratrucks.com



# T 815-7

# T 815-7LOR39 29 2766x6.1R

## 6x6 HMHD CARGO/TROOP CARRIER

### ENGINE

Water cooled, four stroke, turbocharged, aftercooled, direct injection diesel, electronically controlled.

EURO 3 emission level.

Make	CUMMINS
Model	ISLe 375
Numbers of cylinders	6 in-line
Bore/stroke	114/144.5 mm
Displacement	8,850 cm <sup>3</sup>
Max. power output	276 kW (370 bhp)/2,100 RPM
Max. torque	1,550 Nm/1,200 RPM

### TRANSMISSION

Model	TATRA 10TS 210
Manual, no. of gears forward/reverse	6/1
Electronic shift control with semiautomatic and manual mode.	

### TRANSFER CASE

Model	TATRA 2.30 TRK 0.79/1.85
Two-speed, shifted at halt.	

### FRONT AXLE

Steered, driven with swinging half-axles, front-drive disconnection, axle differential lock. Air springs and telescopic shock absorbers. Wheel hub reductions.

### REAR AXLES

Driven, with swinging half-axles, axle and interaxle differential locks. Air springs and telescopic shock absorbers. Wheel hub reductions. Sway bar.

### STEERING

Left hand drive, integral power steering.

### BRAKE SYSTEM

Drum brakes, pneumatically assisted, wedge type self-adjustable brake units, ABS.

Four separate brake systems: service, emergency, parking and engine brake.

### WHEELS

Single tactical tyres on all axles with CTIS.

Tyres	1605	14.00 R20 Tubeless
Discs		20 -10.00 V
Beadlocks		

### CAB

TATRA military, low profile all-steel cab enabling vehicle air transport-ability in C-130. Forward control

cab, tilted. 2 adjustable seats with safety belts, right-left design, roof manhole. Rifle racks, sun visors, HVAC unit. Prepared for add-on armouring.

### DIMENSIONS

Overall width	2,550 mm
Track - front/rear	2,072 mm
Ground Clearance	380 mm
Clearance can be temporarily raised/lowered by suspension on the fly.	

### WEIGHTS

Curb weight	13,900 kg
Payload (max.)	15,100 kg
Gross vehicle weight (max.)	29,000 kg
Max. trailer weight (max.)	18,000 kg
Max. gross combination weight	47,000 kg

### ELECTRIC EQUIPMENT

Circuit voltage	24V, negative pole grounded
Battery	2x12 V, 180 Ah
Alternator	28 V/80A
Black-out electrical system and convoy lights.	

### FUEL TANK

Capacity	320 l
----------	-------

### PERFORMANCE

Top speed	85 km/h (speed limiter)
Grade ability	50 %
Turning circle diameter (curb to curb)	20±1 m
Fording capability	1,200 mm
Crossing ability - trench width	900 mm
Cruising range (on road) cca	500 km
Climbing ability - vertical step	500 mm
Operating ambient temperature	-10 to +55 °C

### EQUIPMENT

Trailer hook, incl. electrical and braking system coupling.

Platform, foldable benches for 22 soldiers, rolled up sides of tarp, access through the rear.

Driver's tools for maintenance and common repairs.

2kg ABC Fire extinguisher, pioneer tools, jack, 2 wheel chocks.

tatratrucks.com



TATRA EXPORT s.r.o.

Areál Tatry 1450/1, 742 21 Kopřivnice, Czech Republic

tel.: +420 556 492 398, fax: +420 556 492 672, e-mail: defence@tatra.cz