

T 815-790R99 38 300 8x8.1R



DEFENCE

8x8 HMHD CHASSIS CAB WITH LOAD HANDLING SYSTEM

The TATRA 8x8 High Mobility Heavy Duty Tactical Truck integrated with military Load Handling System interfaces with NATO STANAG 2413 flatracks, bodies and existing in-service military flatracks and bodies (even with non-standard side rails). System installed height with ISO1C container is minimised under 4m to meet European road regulations.

The container lifting frame stowage assembly is mounted at the front of the subframe. It is used to store the container lifting frame when the vehicle is empty or in flatrack mode. Complete Flatrack Loading or Unloading cycle takes approximately 2 minutes. Flatracks and bodies are locked/unlocked automatically, all operations carried out from the driving position. Complete ISO container Loading or Unloading cycle takes about 5 minutes. ISO containers require external manual lock/unlock operations to attach/detach the lifting frame to the container and to engage/disengage the ISO twistlocks. Load Handling System can handle full payload up to 300mm below ground level. Use of a suitable trailer with a load handling system doubles the load carrying capacity of the unit. The configuration enables the load handling system to handle the following equipment up to 16,500 kg: • ISO 668 20' IC (8 ft) and 1CC (8,5 ft) freight containers • NATO standard Flatracks/Bodies according STANAG 2413 • PLM Flatracks with and without tilt according STB 07-37209-A1 • PLM EMAT 20 70 10 Flatracks • IFR MARS Flatracks • WLP 14t and WLP 14t-2 Flatrack/ Bodies according to DIN 30722 Pt1 and Pt2.

- C-130 transportable • Adjustable vehicle height and clearance • All-wheel drive • Differential locks • CTIS operated on the fly
- Optional add-on armoring kits to be implemented by the end-user when needed.

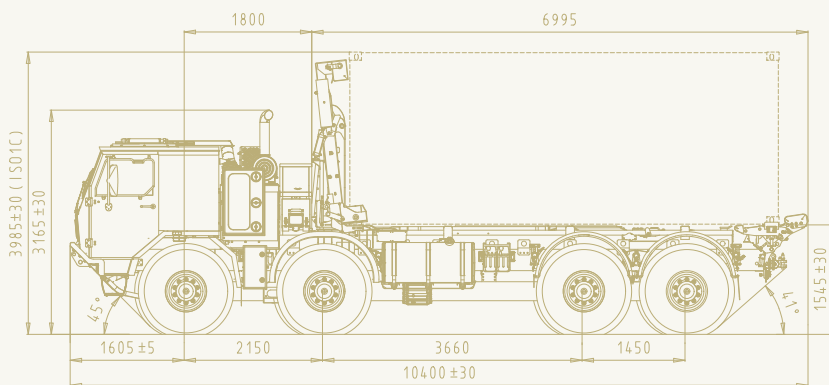

INDEPENDENT SUSPENSION
SOLID 3D STRUCTURE FRAME

18,100 kg PAYLOAD

8x8 DRIVE

300 kW

TATRA TAKES YOU FURTHER



T 815-7

tatratrucks.com

T 815-7 815-7 8x8 HMHD CHASSIS CAB WITH LOAD HANDLING SYSTEM

ENGINE

Air cooled, four stroke turbo-charged and charge-air-cooled direct injection Diesel.

Model	TATRA T3C-928-90 EURO III
Number of cylinders	8
Bore/stroke	120/140 mm
Displacement	12.7 ltrs
Power output	300 kW/1,800 RPM
Max. torque	2,100 Nm/1,000 RPM

CLUTCH

MFZ 1430, single plate, with diaphragm spring. Hydraulic control with pneumatic booster.

TRANSMISSION

Model	TATRA 14 TS 210L
Number of speeds: - forward	14
- reverse	2

Semiautomatic split. Except of the crawler and reverse gears, all gears are synchromeshed.
Option: automated gearshift

TRANSFER BOX

Type TATRA 2.30 TRS 0.8/1.9. Pneumatic control.

FRONT AXLES

TATRA steered and driven swing half-axles with independent wheel suspension, axle differential locks and inter-axle differential lock. Wheel hub reductions. Air springs and telescopic shock absorbers.

REAR AXLES

TATRA driven swing half-axles with independent wheel suspension, axle differential locks and inter-axle differential lock. Wheel hub reductions. Air springs and telescopic shock absorbers, sway bars.

STEERING

Left/right hand drive, integral power steering.

BRAKES

Wedge type self-adjustable drum brake units, ABS. Four separate brake systems: service, emergency, parking, and engine brake.

WHEELS

Single tactical tyres on all axles with CTIS.

Rims	20 -10.00V
Tyres	16.00 R20

Beadlocks, run-flats as option

CAB

COE type, medium size, forward tilting, all-steel, two doors, 2 adjustable seats with safety belts, firm 3rd seat with safety belt, flat 2-piece windscreen, right-left design, roof manhole. Rifle racks, sun visors, HVAC unit. C-130 transportable. Prepared for add-on armouring.

ELECTRIC EQUIPMENT

Nominal voltage	24 V
Batteries	2x12V, 180 Ah
Alternator	80 A/28 V

DIMENSIONS

Width	2,550 mm
Track - front/rear	2,072 mm
Ground clearance	410 mm

Clearance can be temporarily raised/lowered by suspension on the fly.

WEIGHTS

Curb weight	17,700 kg
Payload max.	18,100 kg
GVW max.	35,800 kg
Rated GVW	38,000 kg

PERFORMANCE

Top speed	115 km/h
Gradeability at GVW	60 %
Side slope	45 %
Turning circle diameter (curb to curb)	27±1 m
Fording capability	1,500 mm
Crossing ability - trench width	2,100 mm
Climbing ability - vertical step	600 mm
Fuel tank	420 ltrs
Cruising range (on road)	750 km
Operating ambient temperature	-32°C to +49°C

LOAD HANDLING SYSTEM

Rated lifting capacity 16,500 kg (even 300 mm below ground), and 10% useable overload capacity is available. Interfaces with NATO STANAG 2413 flat-tracks and bodies. Integrated stowable ISO Container Handling Unit. Minimised height to meet European road regulations.



TATRA EXPORT s.r.o.

Areál Tatra 1450/1, 742 21 Kopřivnice, Czech Republic
tel.: +420 556 492 398, fax: +420 556 492 672, e-mail: defence@tatra.cz

tatratrucks.com