

ATTENTION

THIS DOCUMENT IS VALID IF AND ONLY IF YOU PERSONALLY DOWNLOADED IF FROM WWW.BRAY.COM
 IF YOU RECEIVED THIS DOCUMENT FROM ANY OTHER SOURCE, PLEASE TAKE INTO CONSIDERATION THAT ALTERATIONS
 COULD HAVE BEEN MADE, FOR AN ORIGINAL COPY, PLEASE CONTACT BRAY VALVE AT 281-894-5454

Valve Size	A	B	Flange Thk.	C	D	E	F	Top BC	Plate No. of Holes	Drilling Hole Diameter	G	J	Key Size	K	L	Adptr. Code	Weight (Lb.)
22	31.25	6.06	1.53	21.27	24.12	20.12	8.27	6.50	4	.81	2.50	4.00	.62x.62	20.56	16.56	H	475
24	33.00	5.94	1.47	23.28	25.75	19.50	8.27	6.50	4	.81	2.50	4.00	.62x.62	22.70	17.56	H	500
26	35.25	6.50	1.59	24.46	27.83	21.83	11.81	10.00	8	.71	2.50	4.00	.62x.62	23.76	18.82	F25-1	675
28	37.80	6.50	1.59	26.46	29.83	22.84	11.81	10.00	8	.71	2.50	4.00	.62x.62	25.78	19.83	F25-1	735
30	38.75	6.56	1.75	29.29	32.14	23.00	11.81	10.00	8	.71	3.00	4.00	.75x.75	28.73	20.81	F25-2	855
32	41.75	7.48	2.00	30.39	33.78	26.38	11.81	10.00	8	.71	3.00	4.00	.75x.75	29.65	21.94	F25-2	1010
34	44.69	7.88	2.00	33.00	35.82	26.93	13.78	11.73	8	.81	3.50	5.25	.88x.62	32.22	23.66	F30-2	1165
36	46.00	7.88	2.00	35.30	38.25	27.75	13.78	11.73	8	.81	3.50	5.25	.88x.62	34.62	24.94	F30-2	1320

Note 1: K dim is disc chordal dimension at valve face.

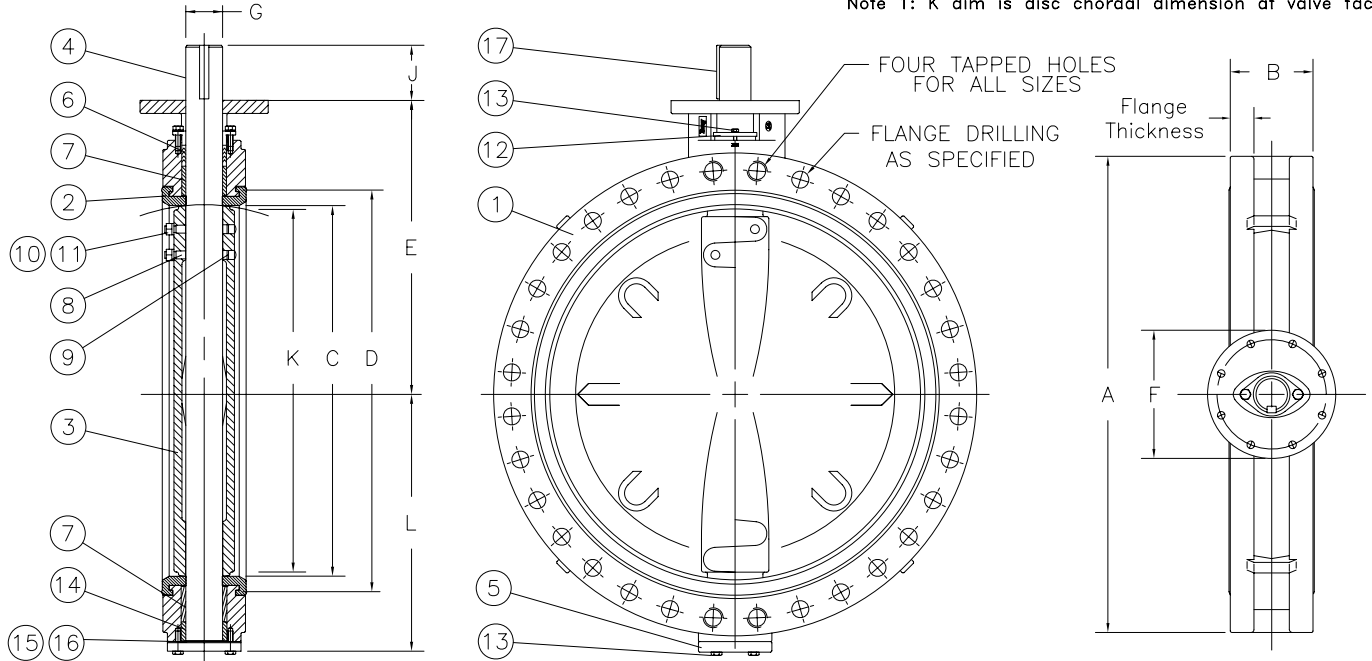

17	KEY	1		
16	GASKET	1		
15	THRUST BEARING	1		
14	RETAINER	1		
13	SCREW	6		
12	PACKING GLAND	1		
11	WASHER	2		
10	NUT	2		
9	O-RING	2		
8	TAPER PIN	2		
7	BEARING	2		
6	PACKING	1		
5	BOTTOM PLATE	1		
4	STEN	1		
3	DISC	1		
2	SEAT	1		
1	BODY	1		

ITEM No.	NAME	QTY	MATERIAL	SPECIFICATION/REMARKS
----------	------	-----	----------	-----------------------

Valve Size _____ Pressure Rating _____ Flg. Drilling _____ Customer/Project _____ Inq./P.O. No. _____ Bray Order No. _____ Certified Correct By _____ Date _____	PARTS LIST AND DIMENSIONS (INCHES) BUTTERFLY VALVE, SERIES 36 150 p.s.i. SIZES 22" THRU 36"	SHEET 1 OF 1 REV. 12 DRAWING NO. ES11A-0050
---	---	---

